

Installation, Operation, and Maintenance Manual

MSVF Series Multistage Vertical External Mount Pumps

60 Hz
MODELS

MSVF 1	MSVF 2
MSVF 3	MSVF 4
MSVF 8	MSVF16
MSVF 32	MSVF 42
MSVF 65	MSVF 85

Table of Contents

INTRODUCTION	03
SPECIFICATIONS–SECTION A	03
MODEL CODE EXPLANATION	03
OPERATING PARAMETERS.....	04
MOTOR DATA	04
INSTALLATION–SECTION B	04
HANDLING	04
REQUIREMENTS	05
ELECTRICAL CONNECTION–SECTION C	05
SPECIFICATIONS	05
CONNECTION	05
ROTATION DIRECTION	05
POSITIONING CONNECTION BOX	05
WIRING DIAGRAM	06
OPERATION AND MAINTENANCE–SECTION D	06
FINAL CHECKS	06
START UP	06
SHUTDOWN.....	07
SEAL MAINTENANCE	07
FROST PROTECTION.....	07
MOTOR LUBRICATION.....	07
SUCTION FILTER.....	07
PERIODIC INSPECTION	07
TROUBLESHOOTING–SECTION E	08
DIMENSIONS–SECTION F	09
MSVF 1 DIMENSIONS, WEIGHTS AND OUTLINE DRAWING.....	09
MSVF 2 DIMENSIONS, WEIGHTS AND OUTLINE DRAWING.....	09
MSVF 3 DIMENSIONS, WEIGHTS AND OUTLINE DRAWING.....	10
MSVF 4 DIMENSIONS, WEIGHTS AND OUTLINE DRAWING.....	10
MSVF 8 DIMENSIONS, WEIGHTS AND OUTLINE DRAWING.....	11
MSVF 16 DIMENSIONS, WEIGHTS AND OUTLINE DRAWING.....	11
MSVF 32 DIMENSIONS, WEIGHTS AND OUTLINE DRAWING.....	12
MSVF 42 DIMENSIONS, WEIGHTS AND OUTLINE DRAWING.....	12
MSVF 65 DIMENSIONS, WEIGHTS AND OUTLINE DRAWING.....	13
MSVF 85 DIMENSIONS, WEIGHTS AND OUTLINE DRAWING.....	13
WARRANTY–SECTION G	14

Please read this manual carefully before beginning installation and operation.

INTRODUCTION

This Installation, Operation, and Maintenance Manual is designed to help you get the best performance and longest life from your RAE pump.

This pump is a MSVF Series vertical multistage external mount pump. This pump should be securely mounted and not immersed during operation. This pump must be primed before operation.

MSVF Series pumps are intended for industrial use to carry fluids such as water, coolant, light oil and other clean, non-aggressive liquids.

Standard pump construction is stainless steel wetted parts. All metal parts in contact with the pumped liquid are made of stainless steel.

If there are any questions regarding the pump or its applications which are not covered in this manual, or in other literature accompanying this unit, please contact your RAE Pumps distributor, or write:

RAE Pumps
1212 Strenge Street
Cincinnati, OH 45223
513.779.3034
Info@RAEPumps.com
www.RAEPumps.com

For information or technical assistance on the power source, contact the power source manufacturer's local dealer or representative.

! DANGER !

This pump is not intended to transfer explosive liquids, such as gasoline, diesel oil and other similar liquids. It is only suitable for water, and diluted, low viscosity, non-corrosive cooling or lubricant liquids.

SPECIFICATIONS—SECTION A

MODEL CODE EXPLANATION

The pump model is shown on the pump nameplate. The pump models are coded based on the number of pump stages. Standard stages consist of both diffusers and impellers.

The number of stages/impellers is followed by a zero in the model code. This zero is not part of the stage count number.

On some models, the model code may be followed by a /1 or /2, this indicates the number of smaller impellers in that model to achieve the desired operating specs. These smaller impellers are included in the total stage/impeller count.

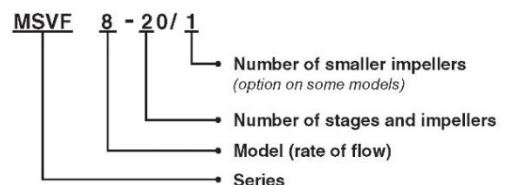
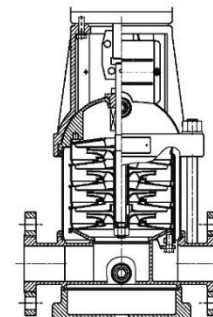

OPERATING PARAMETERS

Ambient temperature: Max 104°F

Liquid temperature range: 5°F to 158°F

	MSVF 1	MSVF 2	MSVF 3	MSVF 4	MSVF 8
Flow (gpm):	3 to 9	4 to 20	7 to 22	11 to 35	30 to 61
Head (feet):	57 to 689	85 to 768	57 to 712	85 to 679	43 to 663
Max psi:	319	341	334	304	290

	MSVF 16	MSVF 32	MSVF 42	MSVF 65	MSVF 85
Flow (gpm):	44 to 114	87 to 211	132 to 285	176 to 439	265 to 572
Head (feet):	62 to 646	62 to 646	95 to 784	85 to 564	101 to 463
Max psi:	290	290	377	261	218

MOTOR DATA

Nominal speed: 3500 rpm at 60 Hz

Standard voltage: 3 phase; 230V/460V

Protection class: IP54

Insulation class: F

INSTALLATION-SECTION B

! WARNING !

When running, the motor surface, column and base temperature is extremely high-especially when high temperature liquids are being pumped. Mount pump in a safe place to avoid accidental touch.

When lifting pumps with motor sizes from 15HP to 148HP, lift the pump using the motor lifting eyes (Figure 2).

HANDLING

When lifting pumps with motor sizes from 0.5HP to 10HP, lift the pump from under the motor flange using straps or other lift equipment (Figure 1).

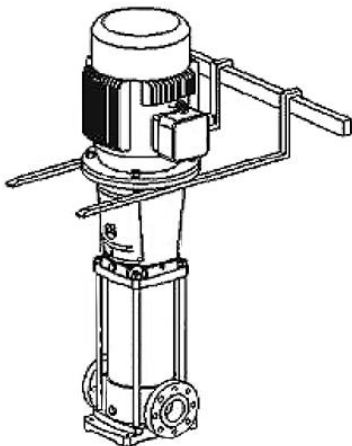

Figure 1

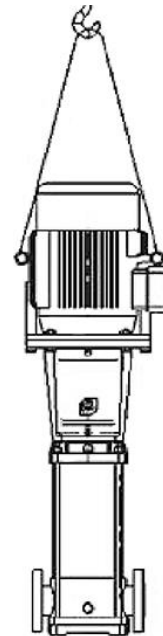

Figure 2

REQUIREMENTS

1. The pump should be located in a well-ventilated but frost-free area.
2. The distance between pump-motor and other objects should be at least 6 inches to avoid overheating.
3. To minimize inlet wear, use the shortest inlet pipe possible.
4. Ensure check valve is installed on discharge pipe. If pump is used for boiler water supply, a check valve must be installed in the piping between the pump and boiler.
5. Pump should be installed on cement base, or other similar base with suitable height. It can also be bolted securely to a wall.
6. When installing the drainage pipe, support pipe weight to avoid strain on the pump and twisting of the pipe.

! WARNING !

Pump should never be mounted with the motor hanging upside down.

7. Arrows on the inlet and outlet indicate the direction of liquid flow through the pump. Verify that liquid can flow easily before starting the pump.
8. Before installation, the inlet pipeline should be cleaned. If the pumped liquid contains

impurities, a strainer should be installed 1.5' to 3' in front of the inlet (particularly recommended for pumps with flows less than 35 gpm).

9. Avoid airlocks when installing the inlet pipe. Refer to **Figure 3**.

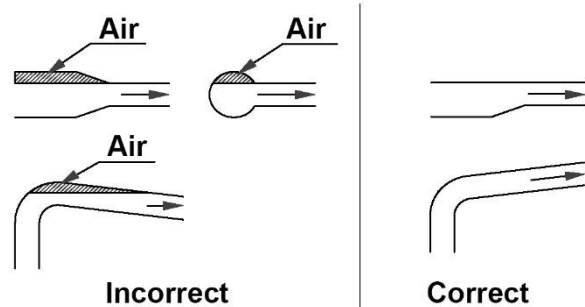

Figure 3

10. Install bypass on outlet pipe to ensure adequate lubrication and cooling.
11. Motor should be correctly grounded. Pump can be damaged by phase loss, unstable power or power surge.
12. Install a pressure meter on pump outlet to monitor pump operation.

ELECTRICAL CONNECTION– SECTION C

! WARNING !

Electrical installation should be carried out in accordance with the local electrical code. Make sure that the electricity supply has been switched off before electrical connection.

Use care when accessing pump electrical components.

SPECIFICATIONS

Electrical specifications (voltage, hertz) are shown on the pump nameplate. Verify that the power supply voltage and hertz match pump requirements. An external ON/OFF switch must be installed.

CONNECTION

Electrical connection should be in accordance with diagram shown on the connecting box, and motor current should be within rated amps as shown on nameplate. Three phase pump requires extra magnetic starter with protection.

ROTATION DIRECTION

On this three phase motor, rotating direction is critical. The rotating direction is indicated on the fan cover (counterclockwise viewing from fan cover end). Interchanging any two leads with power off can reverse the pump rotation.

POSITIONING CONNECTION BOX

The position of the motor connecting box is adjustable. Referring to **Figure 4**, the position can be changed by removing the motor fan cover, unscrewing the frame bolts, and turning

the motor casing and connecting box subassembly together to proper position. Finally, screw the frame bolts tight, and put the fan cover back.

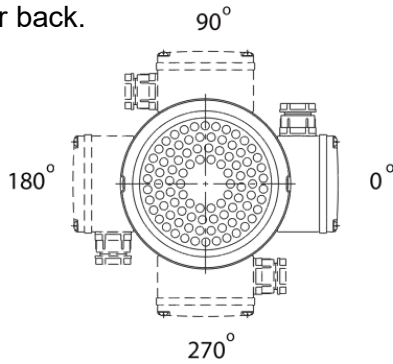
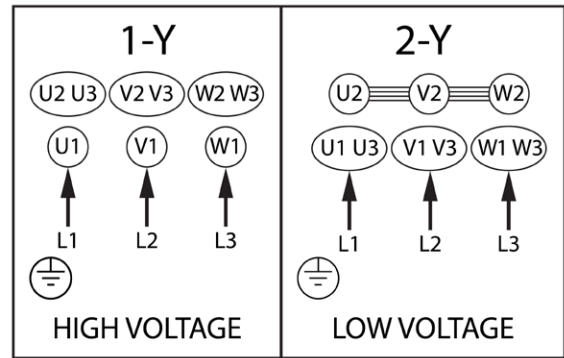

Figure 4

WIRING DIAGRAM



OPERATION AND MAINTENANCE—SECTION D

! WARNING !

The pump cannot be operated with discharge outlet fully closed. Doing so will raise the liquid temperature abnormally, and quickly damage pump.

! WARNING !

The pump cannot be used to transfer explosive liquids.

Extra protective gear is required if the working liquid temperature exceeds 140°F to avoid scald hazard.

The pump should not be used to transfer toxic or contaminated liquid. Warranty will be void if the pump application is not in compliance with the installation and operation procedures.

! CAUTION !

This pump must be primed before start up.

FINAL CHECKS

Before starting the pump, verify:

1. Pump rotation—the rotating direction should be counterclockwise viewing from fan cover end.
2. Piping and joints are fitted carefully to prevent leaks.

3. The pump has been filled with liquid as described in the **START UP** instructions below. Failure to do so will damage the bearing and mechanical seal.
4. The suction filter is clear of obstruction.

START UP

1. Do not start the pump until it has been filled completely with liquid.
2. To fill pump in an inverse pouring system:
 - a. close the pump outlet valve
 - b. release air vent screw on the pump head
 - c. open the inlet valve slowly until stable water flows from the air vent screw
 - d. tighten air vent screw
 - e. open the check valve in the inlet pipeline completely
3. To fill pump in an open system (fill pump when liquid surface is lower than the pump):
 - a. a check valve should be installed on the discharge pipe
 - b. close the pump outlet valve
 - c. release air vent screw on the pump head
 - d. fill the liquid in the pump through the air vent screw hole until pump and inlet pipe are fully filled with liquid
 - e. tighten air vent screw

! CAUTION !

Do not start the pump until it has been fully filled with liquid and air vented.

Ensure air vent screw hole is fully tightened.

Use care, especially in hot water applications, to ensure liquid flow cannot injure people or damage the pump.

4. Start motor, verify motor is turning and is turning in the right direction.
5. Check pressure meter on pump's discharge for fluctuations in pressure and observe pump for vibration. If pressure drops/vibration indicate air in the liquid, loosen air vent bolts to vent air, retighten bolts once pressure stabilizes and vibrations stops.
6. All valves on the inlet pipe should be fully opened and the outlet valve opened slowly after startup.
7. Check all controls for normal operation. If the pump is controlled by a pressure switch, check and adjust the starting and stopping pressure.
8. Check the full load current to make sure it will not exceed the max. current.
9. Observe for changes in the sound of pump operation. If there are any abnormal noises, pump should be stopped and checked immediately.

SHUT DOWN

1. Close outlet valve slowly.
2. Switch off the power.

! WARNING !

Avoid frequent pump shut down and start up.

Pumps with a motor power equal to or less than 5HP should not be restarted more than 100 times per hour. Pumps with a motor power greater than 5HP should not be restarted more than 20 times per hour.

SEAL MAINTENANCE

Mechanical seal will be adjusted automatically. The rotating and stationary parts are lubricated and cooled by the transferring liquid.

When replacing the mechanical seal, the user needn't disassemble the motor on models with power higher than 10HP.

FROST PROTECTION

This pump is suitable for applications in which there may be freezing conditions, if the following precautions are taken:

1. Suitable antifreeze is added to the transferring liquid, OR
2. If antifreeze is not used, pump should be stopped when freezing conditions might occur
3. In either circumstance, pumps not being used should be drained.

MOTOR LUBRICATION

For motor powers less than 7.5HP, lubrication is not needed. For motor power equal to or greater than 7.5HP, fill grease every 5000 running hours.

SUCTION FILTER

For maximum performance, the suction filter should be always kept clean and free from obstructions.

PERIODIC INSPECTION

The following checks should be carried out periodically to ensure normal operation:

1. Measure the discharge and output pressure.
2. Inspect piping and joints for leaks.
3. Measure motor temperature for changes.
4. Examine the motor starter/container.

TROUBLE SHOOTING—SECTION E

! WARNING !

Verify electrical supply has been switched off before trouble shooting.

Fault	Possible Causes	Possible Solutions
Motor does not start	<ol style="list-style-type: none"> 1. No electrical supply 2. Fuses blown or breaker tripped 3. Overheating relay tripped 4. Defective magnetic contact 5. Control circuit malfunction 6. Motor is defective 	<ol style="list-style-type: none"> 1. Check power supply 2. Replace fuses 3. Check system 4. Replace motor starter 5. Check control circuit 6. Repair
Overload device of motor starter trips out immediately when power supply is switched on	<ol style="list-style-type: none"> 1. Fuses are blown 2. Contacts of overload device are faulty 3. Cable connection is loose or faulty 4. Motor winding is defective 5. Pump mechanically blocked 	<ol style="list-style-type: none"> 1. Replace fuses 2. Check motor starter 3. Check cables and power supply 4. Replace motor 5. Check and repair pump
Overload device trips out occasionally	<ol style="list-style-type: none"> 1. The setting for overload is too low 2. Periodic power supply faults 3. Low voltage at peak times 	<ol style="list-style-type: none"> 1. Reset the overload setting 2. Check power supply 3. Add regulator
Motor starter has not tripped out but pump does not run	<ol style="list-style-type: none"> 1. Contacts of starter are not contacted well or the coil is faulty 2. Control circuit is defective 	<ol style="list-style-type: none"> 1. Change motor starter 2. Check control circuit
Pump runs but liquid flow is inconsistent	<ol style="list-style-type: none"> 1. Suction pipe is too small 2. Insufficient liquid in the pump inlet 3. Liquid level is low 4. Pump inlet pressure is too low compared to water temperature, pipeline loss and flow 5. Suction pipe is partially blocked 	<ol style="list-style-type: none"> 1. Enlarge inlet pipeline 2. Improve system and increase incoming liquid 3. Try to lift liquid level 4. Improve system and increase inlet pressure 5. Check and clear debris
Pump runs but no liquid discharges	<ol style="list-style-type: none"> 1. Suction pipe is fully blocked 2. Foot valve or check valve is closed 3. Leak in suction pipe 4. Air in suction pipe or pump 	<ol style="list-style-type: none"> 1. Check and clear debris 2. Check and repair valve 3. Check and repair pipe 4. Refill liquid, vent air
Pump runs backwards when switched off	<ol style="list-style-type: none"> 1. Leak in suction pipe 2. Foot valve or check valve is defective 3. Foot valve is blocked in open or partially open position 4. Air in suction pipe or pump 	<ol style="list-style-type: none"> 1. Check and repair pipe 2. Check and repair valve 3. Check and repair valve 4. Refill liquid, vent air
Abnormal vibration or noise from the pump	<ol style="list-style-type: none"> 1. Leak in suction pipe 2. Suction pipe is too small or blocked by debris 3. Air in suction pipe or pump 4. The pressure requirements of the system are incompatible with rated pressure of the pump 5. Pump mechanically blocked 	<ol style="list-style-type: none"> 1. Check and repair pipe 2. Enlarge/check and clear debris 3. Refill liquid, vent air 4. Improve system or choose another pump model 5. Check and repair pump

DIMENSIONS AND WEIGHT—SECTION F

MSVF1

Model	A	B	C	D	E	Weight (pounds)	Max Inlet Pressure (psi)
	(inches)	(inches)	(inches)	(inches)	(inches)		
MSVF1-20	19.02	10.16	8.86	5.83	4.61	44.09	87
MSVF1-30	19.73	10.87	8.86	5.83	4.61	44.09	87
MSVF1-40	20.43	11.57	8.86	5.83	4.61	46.30	87
MSVF1-50	21.14	12.28	8.86	5.83	4.61	48.50	87
MSVF1-60	21.85	12.99	8.86	5.83	4.61	50.70	145
MSVF1-70	23.74	14.09	9.65	6.69	5.59	57.32	145
MSVF1-80	24.45	14.80	9.65	6.69	5.59	59.52	145
MSVF1-90	25.15	15.51	9.65	6.69	5.59	61.73	145
MSVF1-100	25.87	16.22	9.65	6.69	5.59	63.93	145
MSVF1-110	26.57	16.93	9.65	6.69	5.59	63.93	145
MSVF1-120	27.28	17.64	9.65	6.69	5.59	66.14	145
MSVF1-130	27.99	18.35	9.65	6.69	5.59	68.34	145
MSVF1-150	31.57	20.16	11.41	7.48	6.10	81.57	145
MSVF1-170	32.99	21.57	11.41	7.48	6.10	83.78	145
MSVF1-190	34.41	22.49	11.41	7.48	6.10	90.39	145
MSVF1-210	35.83	24.41	11.41	7.48	6.10	92.59	145
MSVF1-230	37.24	25.83	11.41	7.48	6.10	94.80	145
MSVF1-250	41.22	27.64	13.58	7.76	6.50	112.44	145

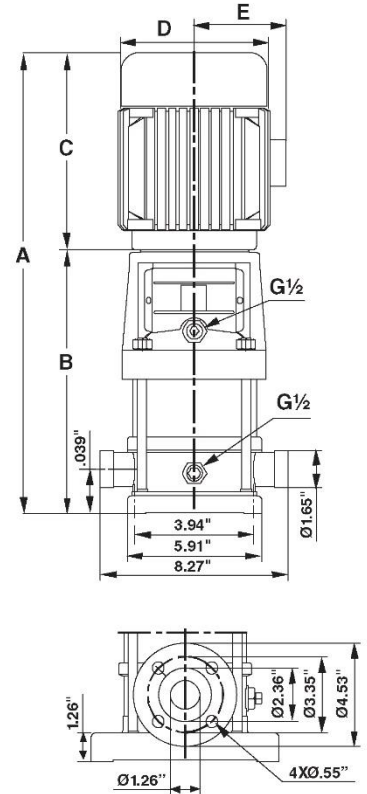

MSVF2

Model	A	B	C	D	E	Weight (pounds)	Max Inlet Pressure (psi)
	(inches)	(inches)	(inches)	(inches)	(inches)		
MSVF2-20	19.02	10.16	8.86	5.83	4.61	46.30	87
MSVF2-30	20.91	11.26	9.65	6.69	5.59	52.91	145
MSVF2-40	21.61	11.97	9.65	6.69	5.59	55.12	145
MSVF2-50	22.32	12.68	9.65	6.69	5.59	57.32	145
MSVF2-60	23.30	13.39	9.65	6.69	5.59	57.32	145
MSVF2-70	25.91	14.49	11.41	7.48	6.10	70.55	145
MSVF2-90	27.32	15.91	11.41	7.48	6.10	79.37	217
MSVF2-110	28.74	17.32	11.41	7.48	6.10	81.57	217
MSVF2-130	32.71	19.13	13.58	7.76	6.50	97.00	217
MSVF2-150	34.13	20.55	13.58	7.76	6.50	99.21	217
MSVF2-180	36.65	22.68	13.98	9.06	7.40	119.05	217

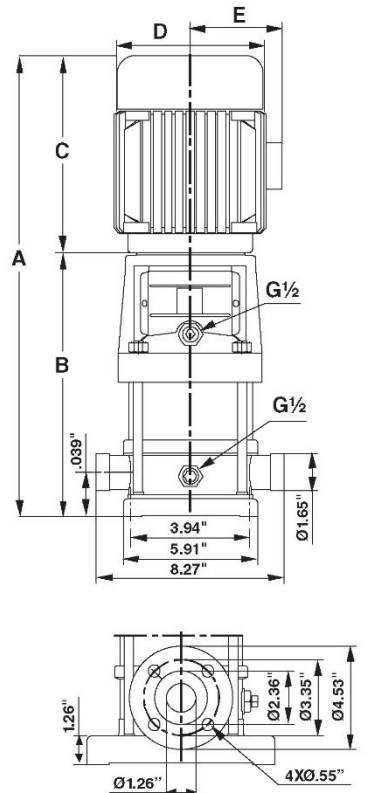

MSVF3

Model	A	B	C	D	E	Weight	Max Inlet Pressure
	(inches)	(inches)	(inches)	(inches)	(inches)		
MSVF3-20	19.02	10.16	8.86	5.83	4.61	44.09	87
MSVF3-30	19.73	10.87	8.86	5.83	4.61	46.30	87
MSVF1-40	20.43	11.57	8.86	5.83	4.61	48.50	87
MSVF3-50	22.32	12.68	9.65	6.69	5.59	55.12	87
MSVF3-60	23.03	13.39	9.65	6.69	5.59	57.32	145
MSVF3-70	23.74	14.09	9.65	6.69	5.59	59.52	145
MSVF3-80	24.45	14.80	9.65	6.69	5.59	59.52	145
MSVF3-90	27.32	15.91	11.41	7.48	6.10	72.75	145
MSVF3-100	28.03	16.61	11.41	7.48	6.10	74.96	145
MSVF3-110	28.74	17.32	11.41	7.48	6.10	74.96	145
MSVF3-120	29.45	17.64	11.41	7.48	6.10	81.57	145
MSVF3-130	30.16	18.74	11.41	7.48	6.10	83.78	145
MSVF3-150	31.57	20.16	11.41	7.48	6.10	85.98	145
MSVF3-170	32.99	21.57	11.41	7.48	6.10	88.18	145
MSVF3-190	36.97	23.39	13.58	7.76	6.50	105.82	145
MSVF3-210	38.39	24.80	13.58	7.76	6.50	108.02	217
MSVF3-230	39.80	26.22	13.58	7.76	6.50	110.23	217
MSVF3-250	41.61	27.64	13.98	9.07	7.40	127.87	217

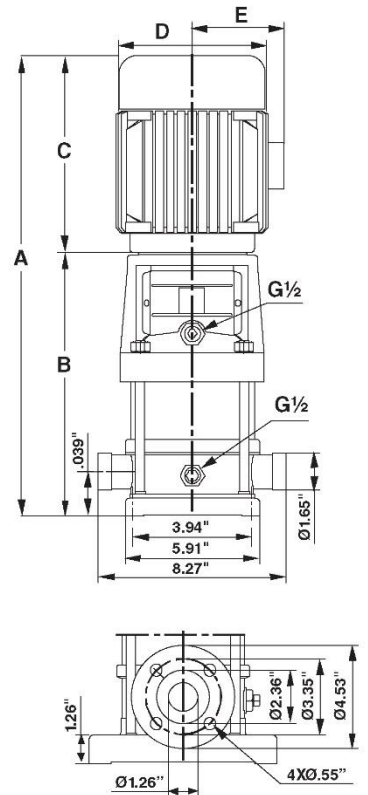

MSVF4

Model	A	B	C	D	E	Weight	Max Inlet Pressure
	(inches)	(inches)	(inches)	(inches)	(inches)		
MSVF4-20	20.91	11.26	9.65	6.69	5.59	52.91	87
MSVF4-30	21.97	12.32	9.65	6.69	5.59	55.12	145
MSVF4-40	25.20	13.78	11.41	7.48	6.10	68.34	145
MSVF4-50	26.26	14.80	11.41	7.48	6.10	74.96	145
MSVF4-60	27.32	15.91	11.41	7.48	6.10	77.16	145
MSVF4-70	30.94	17.36	13.58	7.76	6.50	92.59	145
MSVF4-80	32.00	18.43	13.58	7.76	6.50	92.59	145
MSVF4-100	34.53	20.55	13.98	9.06	7.40	112.44	217
MSVF4-120	36.65	22.68	13.98	9.06	7.40	114.64	217
MSVF4-140	40.94	25.60	15.35	10.23	8.19	141.10	217
MSVF4-160	43.07	27.72	15.35	10.23	8.19	145.50	217

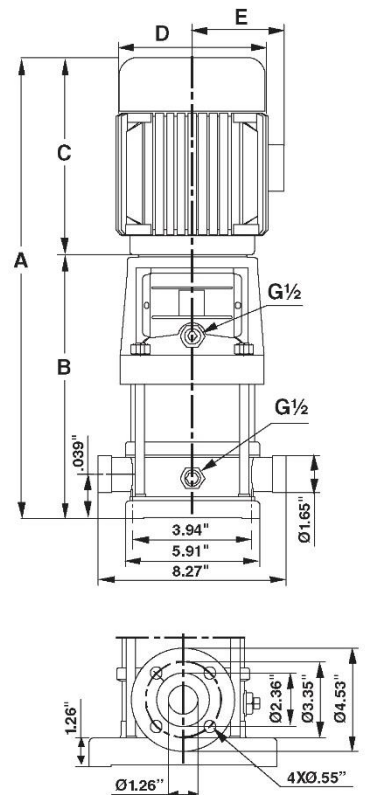

MSVF8

Model	A	B	C	D	E	Weight	Max Inlet Pressure
	(inches)	(inches)	(inches)	(inches)	(inches)		
MSVF8-20/1	23.30	13.66	9.65	6.69	5.59	70.55	87
MSVF8-20	25.40	14.06	11.41	7.48	6.10	83.78	87
MSVF8-30	26.65	15.24	11.41	7.48	6.10	90.39	87
MSVF8-40	30.39	16.81	13.58	7.76	6.50	108.02	87
MSVF8-50	21.57	17.99	13.58	7.76	6.50	110.23	87
MSVF8-60	33.15	19.57	13.98	9.06	7.40	127.87	145
MSVF8-80	37.68	22.32	15.35	10.23	8.19	156.53	145
MSVF8-100	40.04	24.69	15.35	10.23	8.19	176.37	145
MSVF8-120	42.40	27.04	15.35	10.23	8.19	180.78	145
MSVF8-140	52.56	32.87	19.69	12.99	10.04	337.31	145

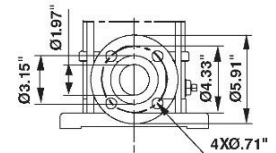
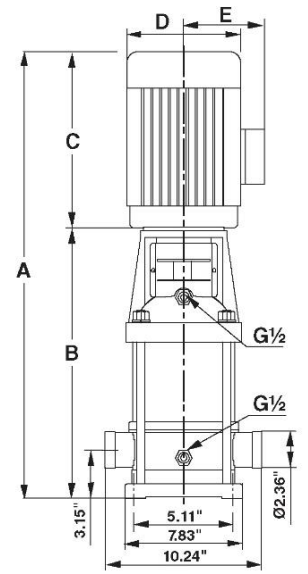

MSVF16

Model	A	B	C	D	E	Weight	Max Inlet Pressure
	(inches)	(inches)	(inches)	(inches)	(inches)		
MSVF16-20/1	27.04	15.63	11.41	7.48	6.10	92.59	87
MSVF16-20	30.00	16.02	13.98	9.06	7.40	123.46	87
MSVF16-30	33.94	18.58	15.35	10.23	8.19	149.91	145
MSVF16-40	35.71	20.35	15.35	10.23	8.19	165.35	145
MSVF16-50	45.28	25.59	19.69	12.99	10.04	326.28	145
MSVF16-60	47.05	27.36	19.69	12.99	10.04	330.69	145
MSVF16-70	48.82	29.13	19.69	12.99	10.04	354.94	145
MSVF16-80	50.59	30.90	19.69	12.99	10.04	359.35	145
MSVF16-100	56.10	34.45	21.65	12.99	10.04	410.06	145

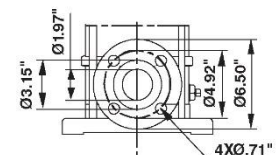
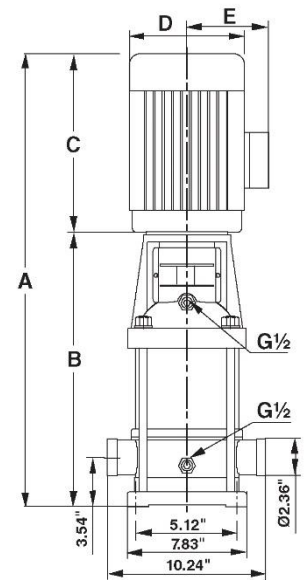

MSVF32

Model	A	B	C	D	E	Weight	Max Inlet Pressure
	(inches)	(inches)	(inches)	(inches)	(inches)		
MSVF32-10/1	33.46	19.88	13.58	7.75	6.50	160.94	45
MSVF32-10	33.85	19.88	13.98	9.06	7.40	178.57	45
MSVF32-20/2	37.99	22.64	15.35	10.23	8.19	209.44	45
MSVF32-20	37.99	22.64	15.35	10.23	8.19	222.67	145
MSVF32-30/2	40.75	25.39	15.35	12.99	10.04	229.28	145
MSVF32-30	49.21	29.53	16.69	12.99	10.04	379.20	145
MSVF32-40/2	51.97	32.28	16.69	12.99	10.04	388.01	145
MSVF32-40	51.97	32.28	16.69	12.99	10.04	410.06	145
MSVF32-50/2	54.72	35.04	16.69	12.99	10.04	421.08	145
MSVF32-50	56.69	35.04	21.65	12.99	10.04	465.18	145
MSVF32-60/2	59.45	37.80	21.65	12.99	10.04	476.20	145
MSVF32-60	59.45	37.80	21.65	12.99	10.04	476.20	145
MSVF32-70/2	63.19	40.55	22.64	14.17	11.22	562.18	145
MSVF32-70	63.19	40.55	22.64	14.17	11.22	562.18	145
MSVF32-80/2	65.94	43.31	22.64	15.75	12.20	571.00	217
MSVF32-80	68.90	43.31	22.59	15.75	12.20	694.46	217
MSVF32-90/2	71.65	42.06	22.59	15.75	12.20	703.28	217
MSVF32-90	71.65	42.06	22.59	15.75	12.20	703.28	217
MSVF32-100/2	74.41	48.82	22.59	15.75	12.20	714.30	217
MSVF32-100	74.41	48.82	22.59	15.75	12.20	714.30	217

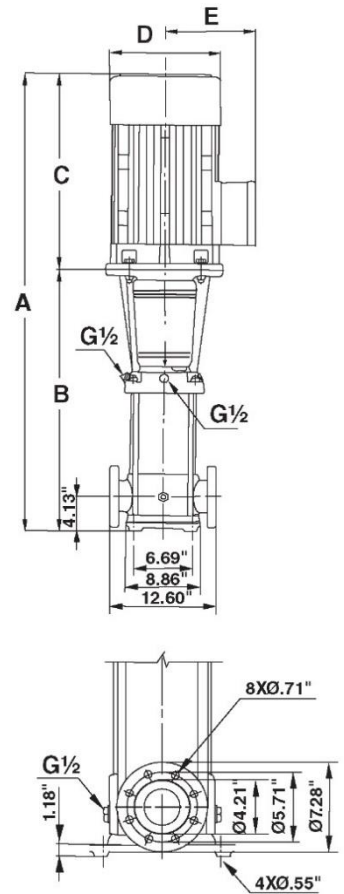

MSVF42

Model	A	B	C	D	E	Weight	Max Inlet Pressure
	(inches)	(inches)	(inches)	(inches)	(inches)		
MSVF42-10/1	37.48	22.09	15.37	10.23	8.19	222.67	58
MSVF42-10	37.48	22.09	15.37	10.23	8.19	233.69	58
MSVF42-20/2	49.13	29.45	16.69	12.99	10.04	329.42	58
MSVF42-20	49.13	29.45	16.69	12.99	10.04	414.47	145
MSVF42-30/2	32.60	21.65	54.25	12.99	10.04	469.59	145
MSVF42-30	32.60	21.65	54.25	12.99	10.04	469.59	145
MSVF42-40/2	58.39	35.75	22.64	14.17	11.22	557.77	145
MSVF42-40	61.34	35.75	25.59	15.75	12.20	681.23	217
MSVF42-50/2	64.49	38.90	25.59	15.75	12.20	690.05	217
MSVF42-50	64.49	38.90	25.59	15.75	12.20	690.05	217
MSVF42-60/2	67.64	42.05	25.59	15.75	12.20	749.57	217
MSVF42-60	67.64	42.05	25.59	15.75	12.20	749.57	217
MSVF42-70/2	72.17	45.20	26.97	18.11	13.39	890.67	217
MSVF42-70	72.17	45.20	26.97	18.11	13.39	890.67	217

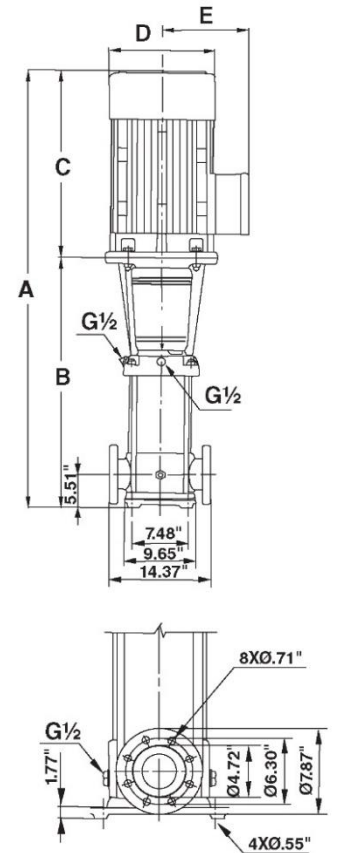

MSVF65

Model	A	B	C	D	E	Weight	Max Inlet Pressure
	(inches)	(inches)	(inches)	(inches)	(inches)		
MSVF65-10/1	37.44	22.09	15.37	10.23	8.19	240.30	58
MSVF65-10	46.10	26.41	16.69	12.99	10.04	390.21	58
MSVF65-20/2	49.37	29.69	16.69	12.99	10.04	412.26	58
MSVF65-20	52.32	29.69	22.64	14.17	11.22	546.75	145
MSVF65-30/2	55.55	32.91	22.64	14.17	11.22	555.57	145
MSVF65-30	58.50	32.91	25.59	15.75	12.20	690.05	217
MSVF65-40/2	61.77	36.18	25.59	15.75	12.20	740.75	217
MSVF65-40	63.15	36.18	26.97	18.11	13.39	877.44	217
MSVF65-50/2	66.38	39.41	26.97	18.11	13.39	886.26	217

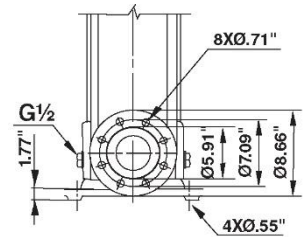
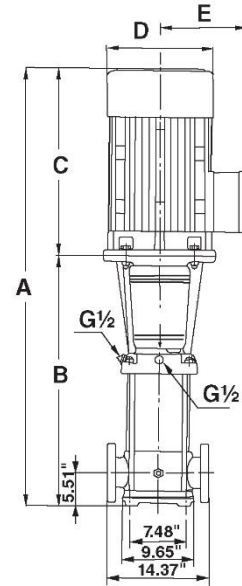

MSVF85

Model	A	B	C	D	E	Weight	Max Inlet Pressure
	(inches)	(inches)	(inches)	(inches)	(inches)		
MSVF85-10/1	42.17	22.48	16.69	12.99	10.04	390.21	58
MSVF85-10	42.17	22.48	16.69	12.99	10.04	414.47	58
MSVF85-20/2	52.09	30.43	21.65	12.99	10.04	465.18	145
MSVF85-20/1	53.07	30.43	22.64	14.17	11.22	546.75	145
MSVF85-20	56.02	30.43	25.59	15.75	12.20	670.20	145
MSVF85-30/2	59.65	34.06	25.59	15.75	12.20	727.53	217
MSVF85-30/1	59.65	34.06	25.59	15.75	12.20	727.53	217
MSVF85-30	61.02	34.06	26.97	18.11	13.39	864.21	217
MSVF85-40/2	64.65	37.68	26.97	18.11	13.39	873.03	217
MSVF85-40	64.65	37.68	26.97	18.11	13.39	873.03	217

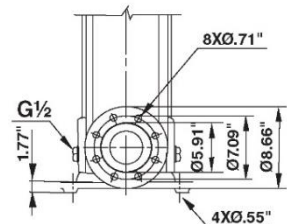
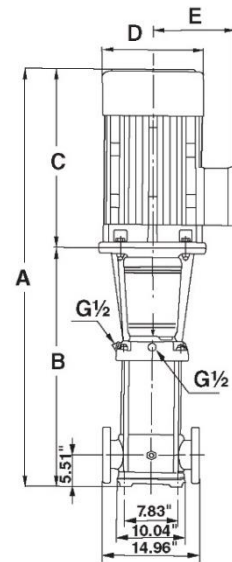

WARRANTY-SECTION G

RAE Pumps will replace, within one year of shipment from our plant, any pump that, in our judgment, has failed due to defects in materials or workmanship, provided the pump has been properly installed and maintained and has not been subject to abuse.

Modifications, including removal of pump tags or misapplication, void this warranty.

Pump must return to RAE Pumps with complete history of service for inspection and warranty consideration.

RAE Pumps does not accept the responsibility for transportation to and from our plant. Furthermore, we do not assume any responsibility for consequential damage or loss of production.